

Datasheet for #sbcw14898 DN

Recommendations:

Please read the User Manual and have a look at the FAQ at <http://www.alpeslasers.ch/?a=142>

WARNING: Operating the laser with higher current or voltage than specified in this document may cause damage and will result in loss of warranty, unless Alpes Lasers has permitted to do so!

WARNING: Beware of the polarity of the laser. This laser has to be powered with negative bias and positive bias on the specific zones drawn below. To be used with a high compliance CW laser driver capable of reaching the operating current and voltage indicated in this datasheet, or up to 2.5A/20V.

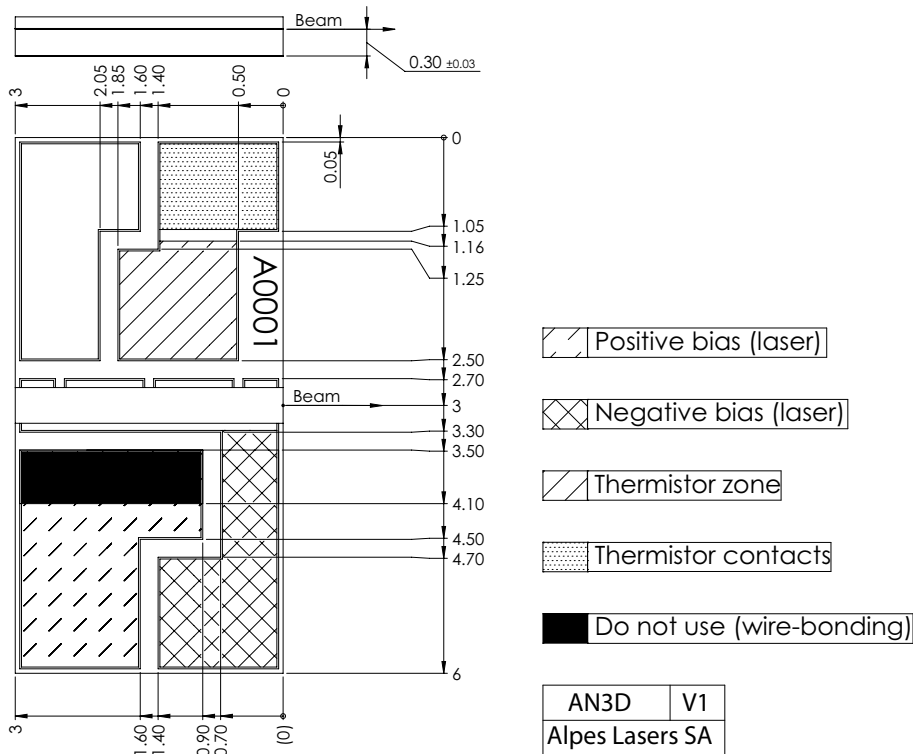

Figure 1: Mechanical and electrical interface for #sbcw14898 DN (please note that AlN submount numbering is P0869)

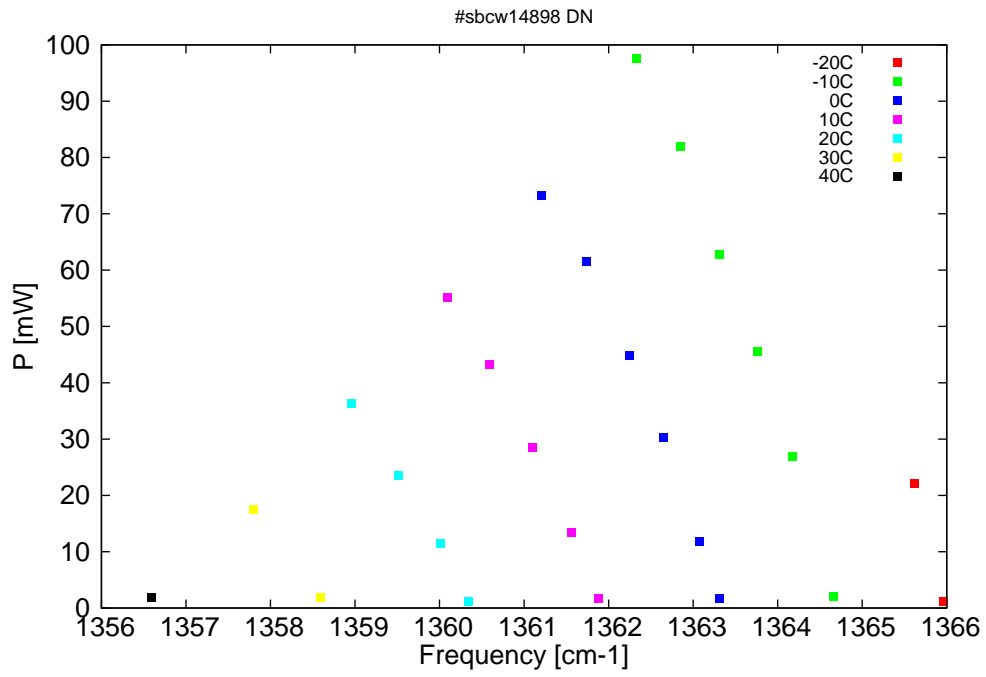

Figure 2: Output power as a function of the singlemode emission frequencies and temperatures

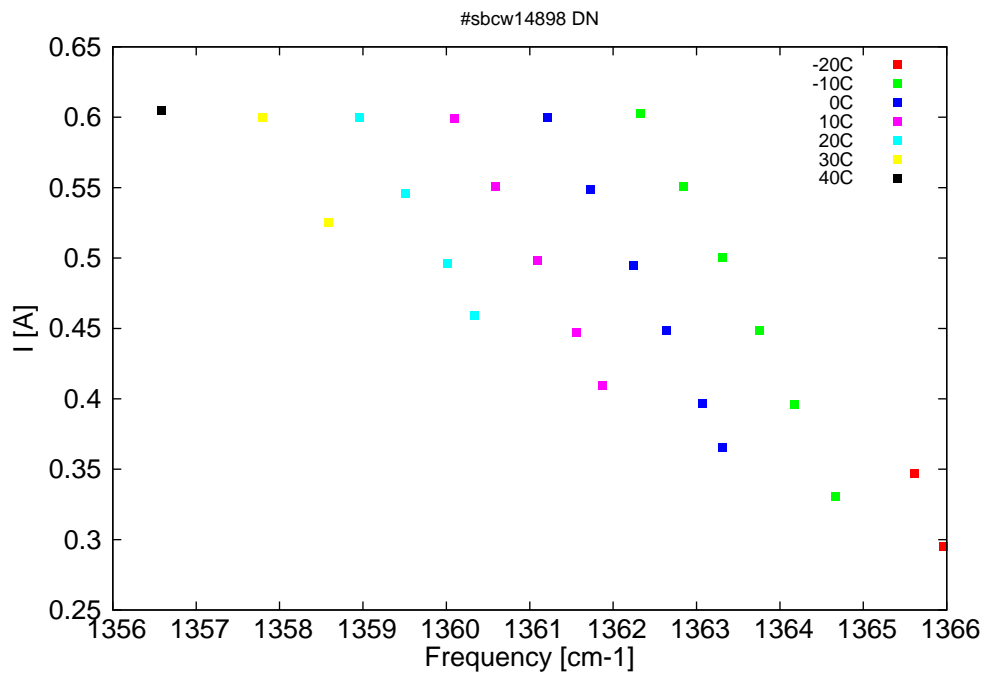

Figure 3: Applied DC current as a function of singlemode emission frequencies and temperatures

λ [nm]	ν [cm ⁻¹]	P[mW]	Temp[°C]	U_{LASER} [V]	I[A]
7320.8	1366	1.2	-20	8	0.29
7322.7	1365.6	22.1	-20	8.2	0.35
7327.8	1364.7	2.1	-10	8.1	0.33
7330.5	1364.2	27	-10	8.3	0.4
7332.7	1363.8	45.6	-10	8.5	0.45
7335.1	1363.3	62.8	-10	8.7	0.5
7337.6	1362.8	82	-10	8.9	0.55
7340.4	1362.3	97.5	-10	9.1	0.6
7335.1	1363.3	1.8	0	8.1	0.37
7336.4	1363.1	11.9	0	8.3	0.4
7338.7	1362.6	30.3	0	8.4	0.45
7340.8	1362.2	44.9	0	8.6	0.49
7343.6	1361.7	61.5	0	8.8	0.55
7346.4	1361.2	73.3	0	9	0.6
7342.8	1361.9	1.7	10	8.3	0.41
7344.5	1361.6	13.4	10	8.4	0.45
7347	1361.1	28.4	10	8.6	0.5
7349.7	1360.6	43.3	10	8.8	0.55
7352.4	1360.1	55.2	10	9	0.6
7351.1	1360.3	1.2	20	8.4	0.46
7352.9	1360	11.5	20	8.5	0.5
7355.6	1359.5	23.6	20	8.7	0.55
7358.6	1359	36.3	20	8.9	0.6
7360.6	1358.6	1.9	30	8.6	0.53
7364.9	1357.8	17.5	30	8.9	0.6
7371.4	1356.6	1.9	40	8.9	0.6

Table 1: Singlemode optical output power as function of operating parameters.

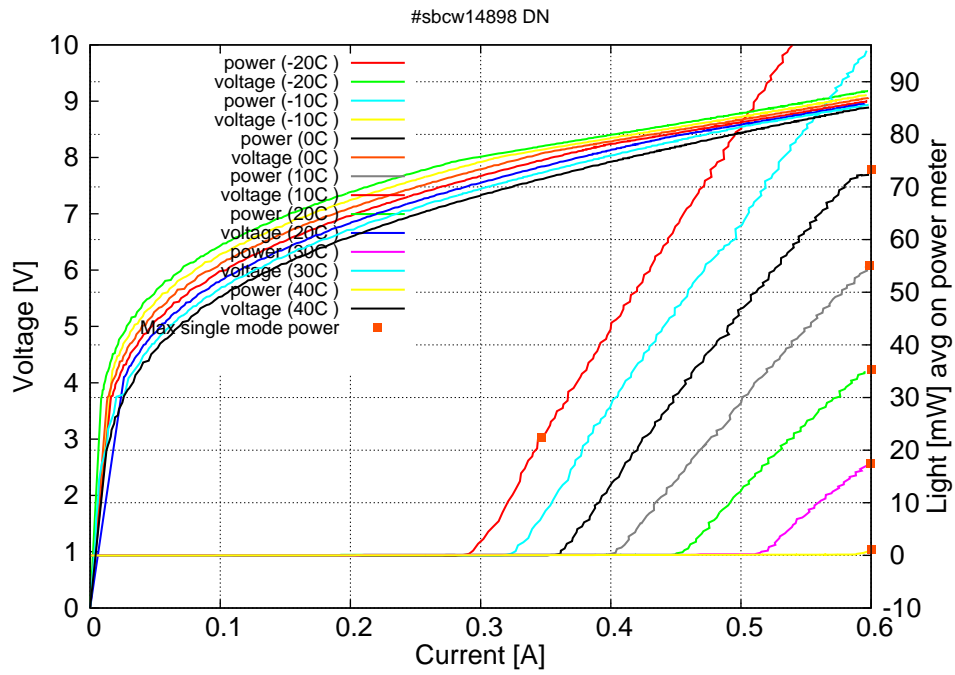

Figure 4: voltage and avg power vs current in continuous-wave operation (the solid squares indicate the maximum singlemode emitted power)

Note: at -20C: $I_{th}=0.29A$ / $V_{th}=8.0V$ (2-wires measurements). Maximum operation current: 0.600A for all temperatures.

Figure 3: spectra at different temperatures for various DC currents

